

Technical Handbook

SE 550-08-25-1

Part 2

**Instructions for Mobile Radio
Installation**

TABLE OF CONTENTS

		Page
2	INSTRUCTIONS FOR MOBILE RADIO INSTALLATION	2-1
2.1	General	2-1
2.2	Set of required tools	2-1
2.3	Radio Unit Cradle	2-1
2.4	Power Supply	2-2
2.4.1	Positive Lead	2-2
2.4.2	Negative Lead	2-2
2.4.3	Fuse	2-2
2.4.4	Wire cross section	2-2
2.4.5	Lead routing	2-3
2.5	Antenna Mounting	2-3
2.6	Handset/Microphone Mounting	2-4
2.7	External Speaker	2-4
2.8	Putting into Service	2-4
2.9	Electromagnetic Compatibility	2-4
2.10	Installation Diagrams	2-5
2.10.1	Measurement Drawing SE 550	2-5
2.10.2	Overview External Connectors SE 550	2-6
2.10.3	Cabling	2-8
2.10.4	Installation on the Simple Mounting Holder	2-9
2.10.5	Installation on the Plugging Holder	2-10
2.10.6	Version with Remote Control Unit	2-12
2.11	Drilling Plan for the Radio Unit Cradle	2-13
2.12	Drilling Plan for the Loudspeaker, Microphone-Rod, Control Unit	2-15
2.13	Accessories (Option)	2-17

2 INSTRUCTIONS FOR MOBILE RADIO INSTALLATION

2.1 General

Installation is to be performed along electrical safety guidelines for installations in vehicles.

Ascom radio units are manufactured only for negative chassis 12 V vehicular power supplies. For installation in vehicles with other polarities or voltages please refer to your distributor or the manufacturer.

2.2 Set of required tools

- o Socket puncher for feed-through holes
- o Electric drill
- o High speed drill set 2 to 10 mm
- o Soldering iron and solder
- o Set of straight blade screwdrivers
- o Set of pozidriv screwdrivers
- o Set of open ended spanners
- o Universal pliers
- o Wire cutter & stripper
- o Reflectometer/VSWR-bridge

2.3 Radio Unit Cradle

Select a safe and convenient place for the cradle holding the radio unit, such that:

- o the radio unit can be operated conveniently by a user with seat belts on, with the radio display well readable
- o the ventilation outlets neither are blocked or blow onto the radio
- o the radio does not hinder passengers in entering/leaving the vehicle
- o the radio does not present a hazard to occupants in case of a collision (e.g. knee protection)

In order to avoid interferences/suceptibilities with/from other vehicular electric systems on board (ignition system, injection control system, ABS anti-skid, etc.), it is recommended to route the radio's power supply cables as far as possible away from these systems. Consult your car manufacturer's recommendations for best installation places.

The cradle should be mounted on a flat surface, large enough to accomodate the whole mounting plate. This will guarantee a solid hold and connection ease.

Use the supplied self threading screws and the template to install (refer to section 2.11) the cradle.

Free and good ventilation around the finned heat sink area is essential. There should be at least 20 mm free space to the rear, above and below for air circulation. Avoid installing the radio in the glove compartment if it will be used for long periods of time. Otherwise a heat build-up will cause a self-protecting reduction in rf-output power, which will impair the communication quality.

2.4 Power Supply

Please refer to installation diagram/pictures in sections 2.10.3 to 2.10.6.

2.4.1 Positive Lead

The positive lead (red) is to be routed directly from the battery's positive (+) pole and must include an in-line fuse (refer to section 2.4.3) within a fuseholder placed as close as possible to the battery.

Use existing feed-through holes where possible. If additional feed-through holes have to be made, they should be fitted with a rubber grommit or similar protection.

2.4.2 Negative Lead

The negative lead (black) must be connected on the shortest possible way to the chassis using the ring cable connector, and never be connected directly to the negative (-) pole of the battery. See the diagram 1 in section 2.10.3. Otherwise noise loops exist which will cause annoying noise effects in the radio (mainly alternator generated noise).

2.4.3 Fuse

The required fuse (value 8 A) to protect the supply line, is to be fitted as close as possible to the battery.

Insert the fuse only after completion and last check of the wiring, before the radio is to be taken into operation.

2.4.4 Wire cross section

For lead lengths up to 2,5 m use a wire with 2,5 mm² cross section. Longer leads will require 4 mm². Be aware that leads with insufficient cross section cause voltage brown-outs leading to severe malfunctions of the radio.

2.4.5 Lead routing

Keep leads such that a short and neat wiring installation is achieved. Pay attention not to lay the leads over sharp edges etc., which will end up in shorts through isolation damage. A good practice is the use of flexible plastic tube insulation. When routing through feed-through holes, check for rubber grommit protection on sharp edges.

2.5 Antenna Mounting

The transmission quality of a radio link depends to a high extent on the antenna itself and its placement.

To reduce the rf-attenuation due to antenna cable losses, the length of this cable is to be kept as short as possible. Avoid mounting the antenna close to the engine, as this may lead to interference.

The antenna outlet of the radio has been designed for a 50 Ohm nominal load. This nominal value will be presented by the antenna only if the operating frequency range is correct. A mismatch in antenna or antenna cable will cause a reduction in rf-output power.

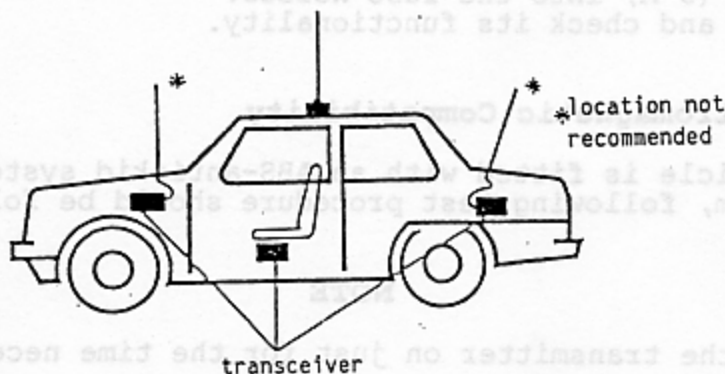

Best results are achieved with an antenna mounted vertically in the centre of the roof area.

If mounting in the roof centre is not feasible, keep mounting holes at least 300 mm from the edge of the roof.

An antenna mounted on the wing will cause strong lobing of the radiation pattern with pronounced directional negative effects.

The mounting surface around the antenna base flange should be cleared from varnish/priming colour to ensure a satisfactory ground connection. Antenna efficiency depends largely on the quality of the ground contact.

Use only 50 Ohm coaxial cable of proven quality of the types RG-58/U, RG-223/U or similar types. If the antenna lead is longer than 5 m, RG-213/U is recommended.

Recapitulating:

- o Mount the antenna vertically and as high as possible
- o Avoid mounting the antenna close to the vehicle's engine
- o Keep antenna lead as short as possible

2.6 Handset/Microphone Mounting

Choose an appropriate place for the cradle. Mark the holes from the template (refer to section 2.12) or from the base plate.

2.7 External Speaker

The external speaker is mounted on a convenient spot and wired with a 2 x 0,75 mm² wire to the speaker connectors. Polarity of the cabling is irrelevant. Mark the holes from the template (refer to section 2.12) and refer to the installation diagrams in section 2.10.4 to 2.10.6.

2.8 Putting into Service

Re-check the wiring against possible errors.
Insert the radio unit into the cradle, until it locks in.
Insert the fuse (8 A) into the fuse holder.
Switch radio on and check its functionality.

2.9 Electromagnetic Compatibility

In case the vehicle is fitted with an ABS-antiskid system or electronic injection system, following test procedure should be followed:

NOTE

Turn the transmitter on just for the time necessary.

Test: Vehicle at rest, parking hand-brake pulled on.
Engine at high idle RPM. Activate transmission key (PTT). The ABS pilot lamp should not light up. The engine should keep running smoothly.

ATTENTION

If malfunction of brakes or ignition/injection is observed, re-route antenna cable, check antenna ground contact. In case of a plastic roof: make a ground plane by glueing a sheet metal foil (either 1/2 wavelength in diameter or side length) from the inside and connect it to the antenna base.

2.10 Installation Diagrams

2.10.1 Measurement Drawing SE 550

NOTE: All measurements given in mm

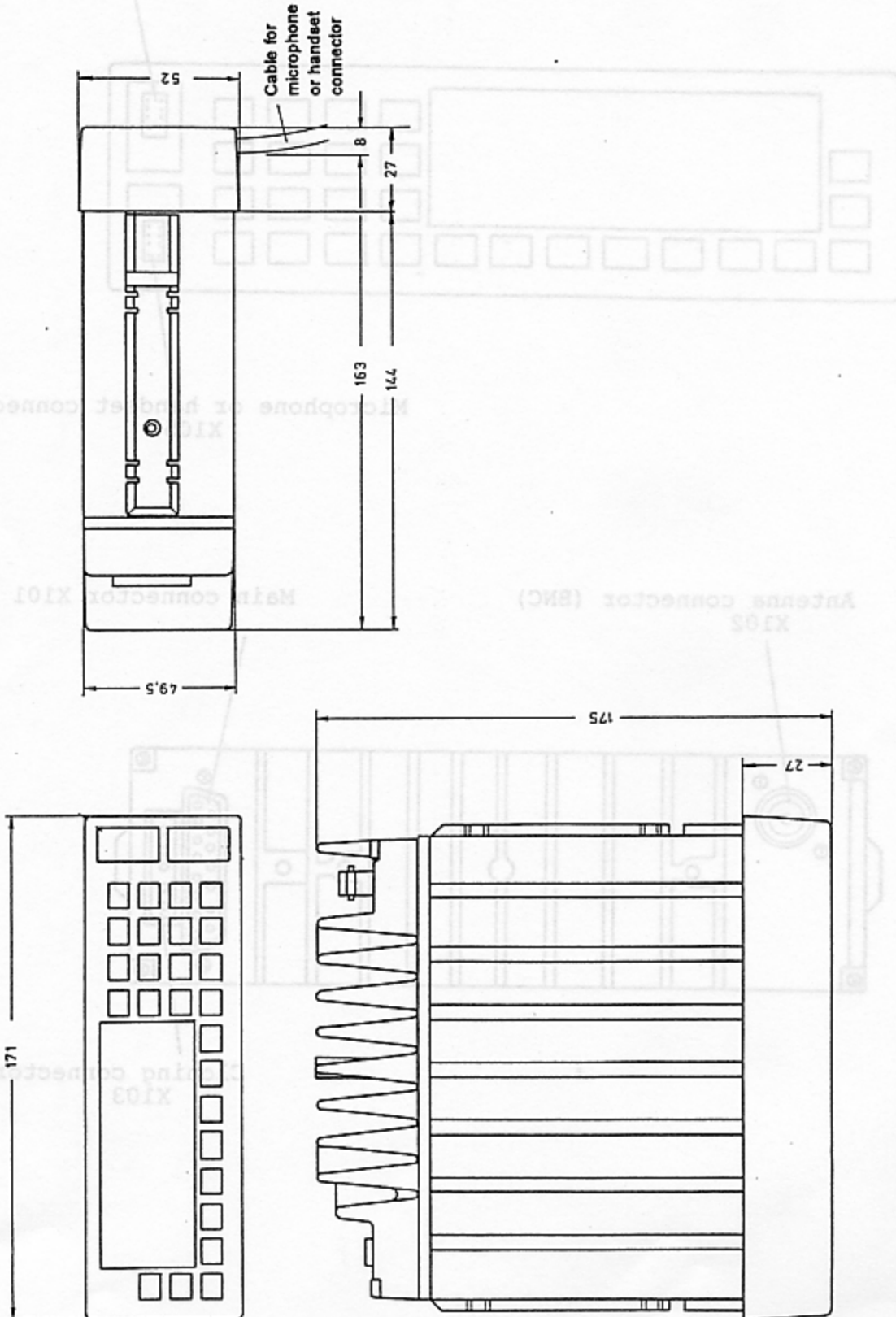

2.10.2 Overview External Connectors SE 550

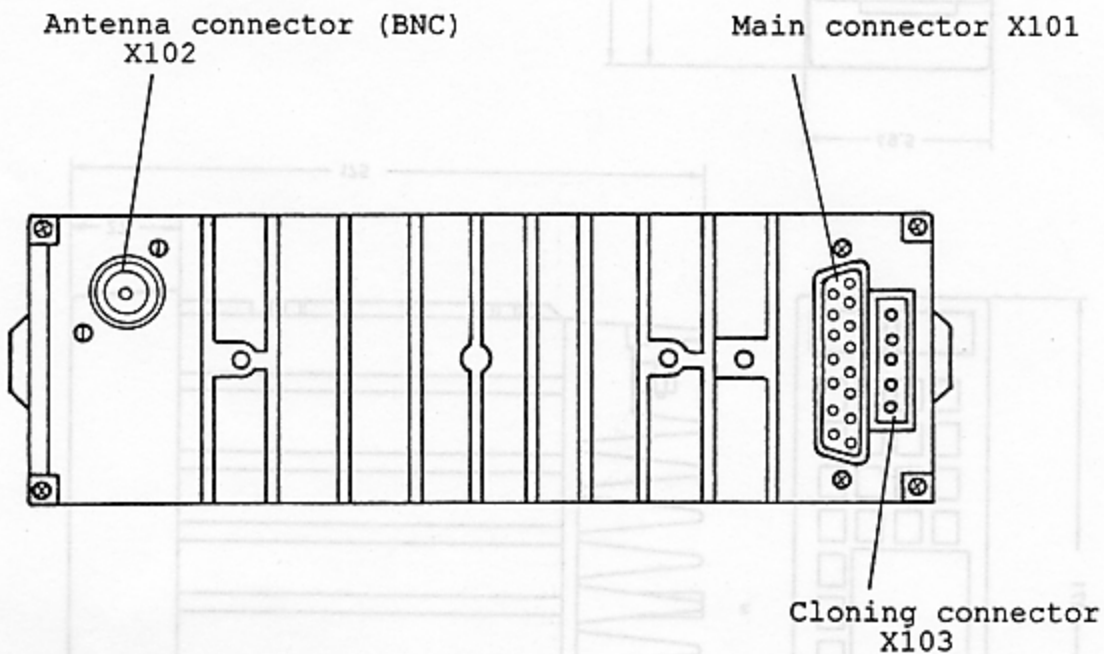
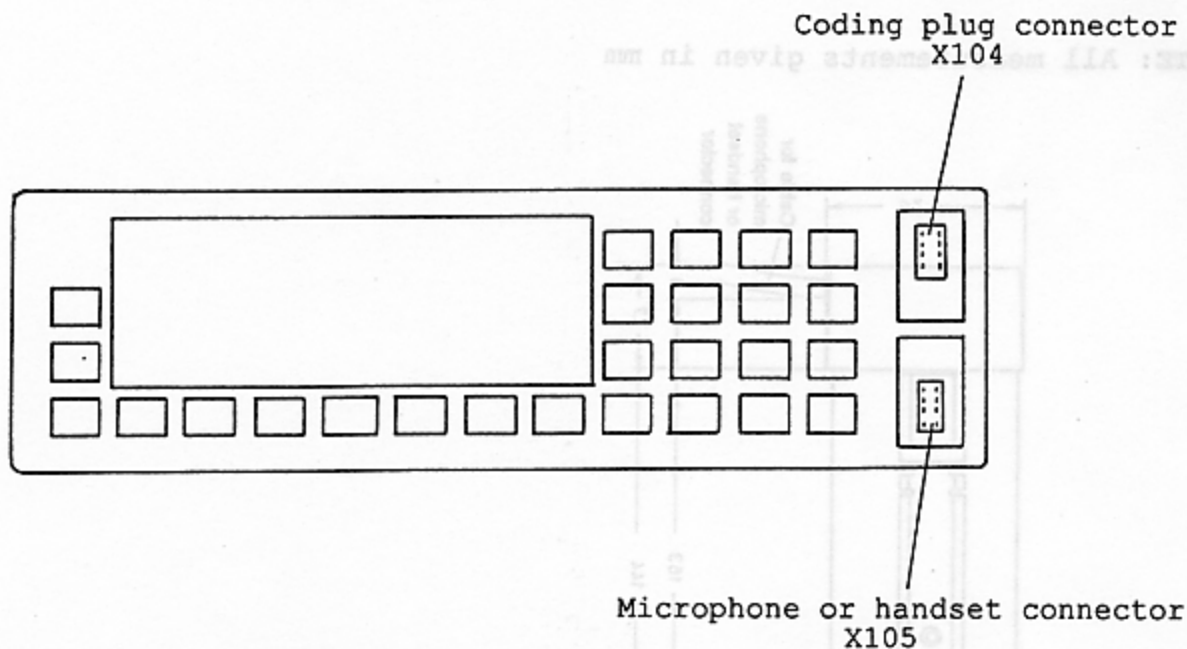

Views of the
 connecting side

X101

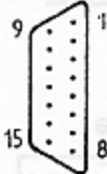

+UB	1	+ UB } battery voltage
+UB	2	+ UB } (prot. by external fuse)
LSP⊥	3	Loudspeaker 4 Ω
AS	4	Signalization, max. 12 V, 500 mA (BC817)
Res	5	Free
AF Ear	6	AF Earphone (600 Ω)
Gnd	7	Ground
Gnd	8	Ground
RF-10dB	9	RF power reduction - 10 dB
LSP~	10	Loudspeaker
PTT A	11	active = L
AFIN	12	AF 600 mV
Emerg.	13	Emergency contact, active = L
+9V	14	+ 9 V •→
Mic A~	15	Microphone 100 m V

X103

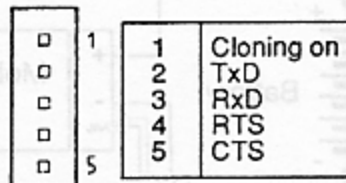

X105

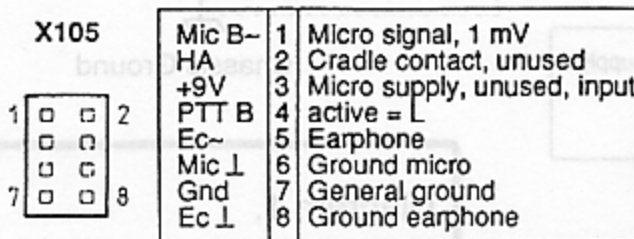

2.10.3 Cabling

Do NOT wire your radio this way:

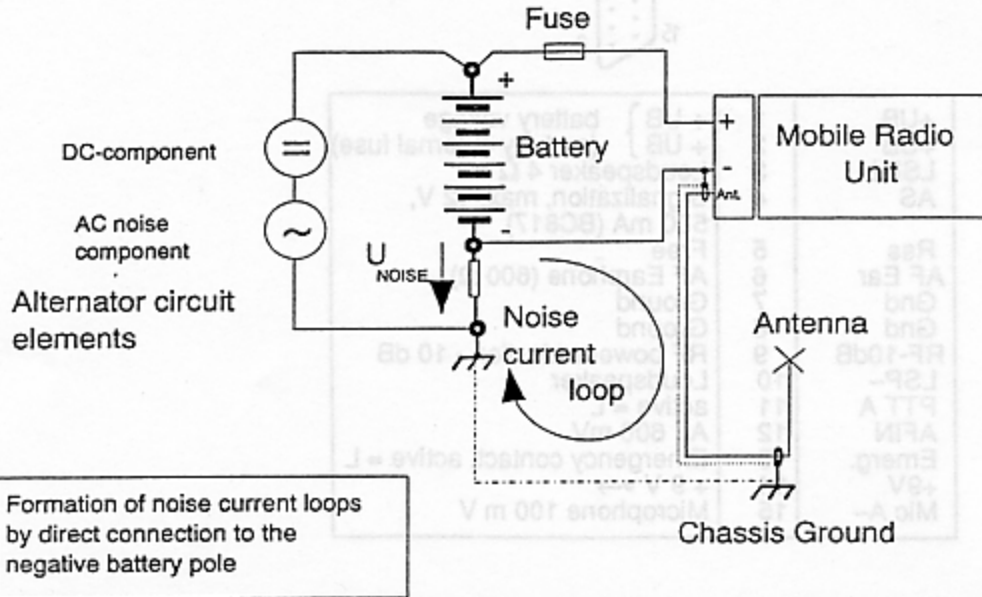

Recommended wiring:

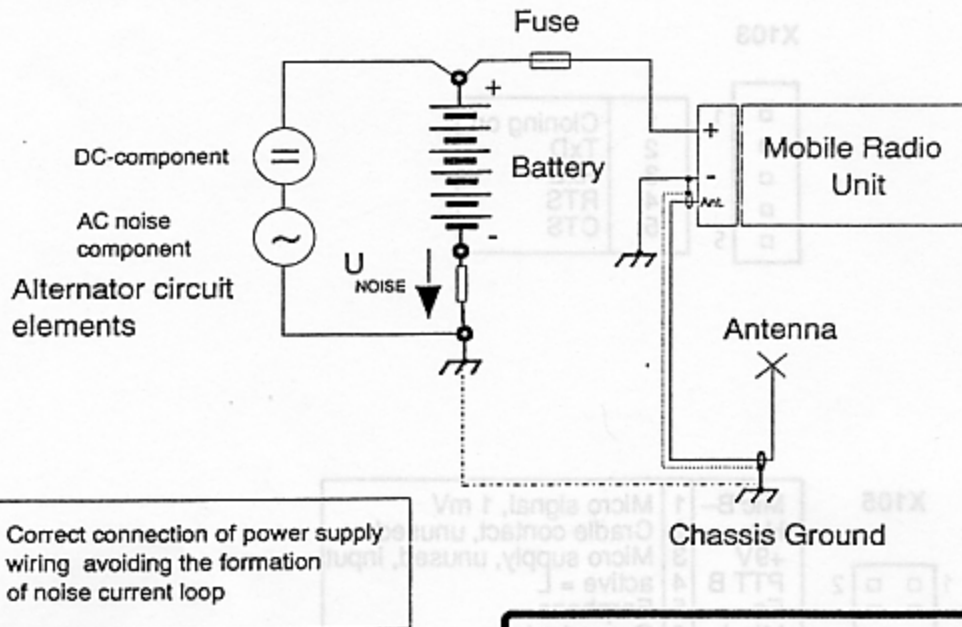
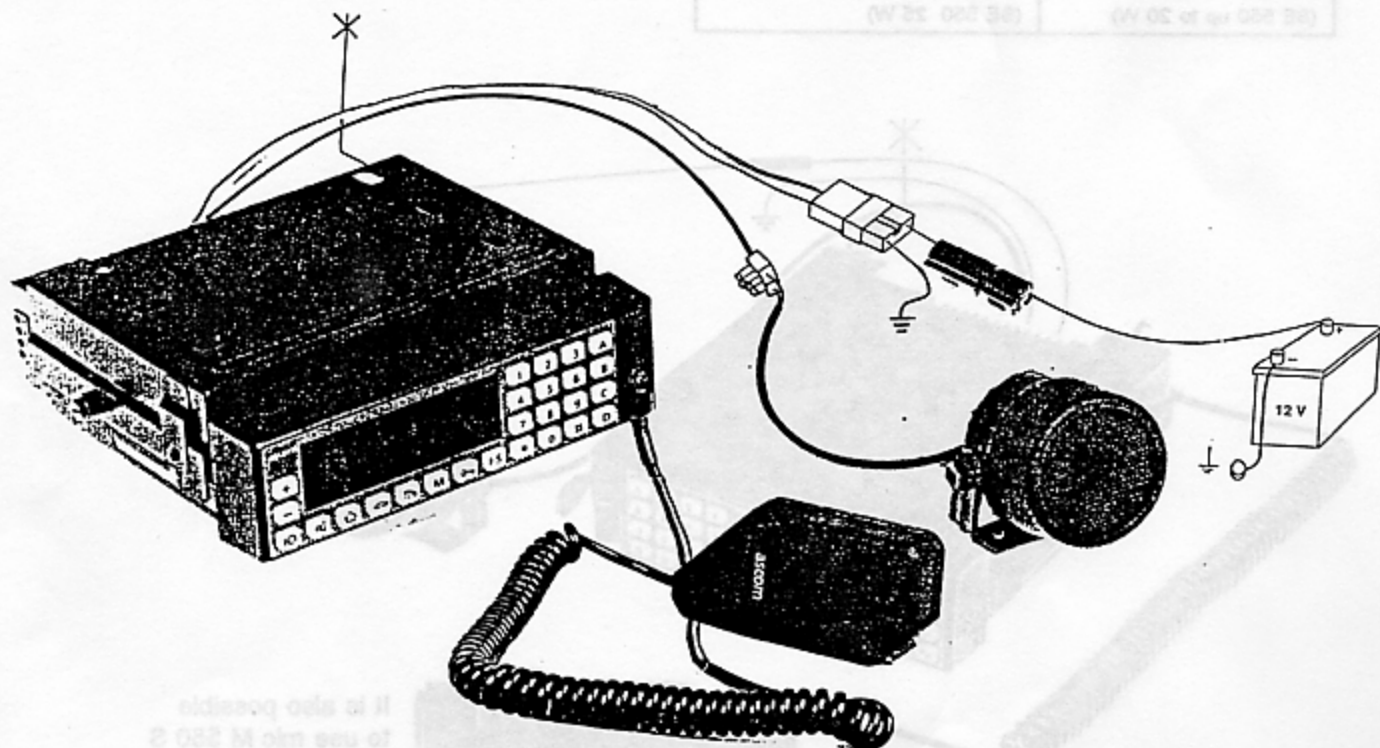
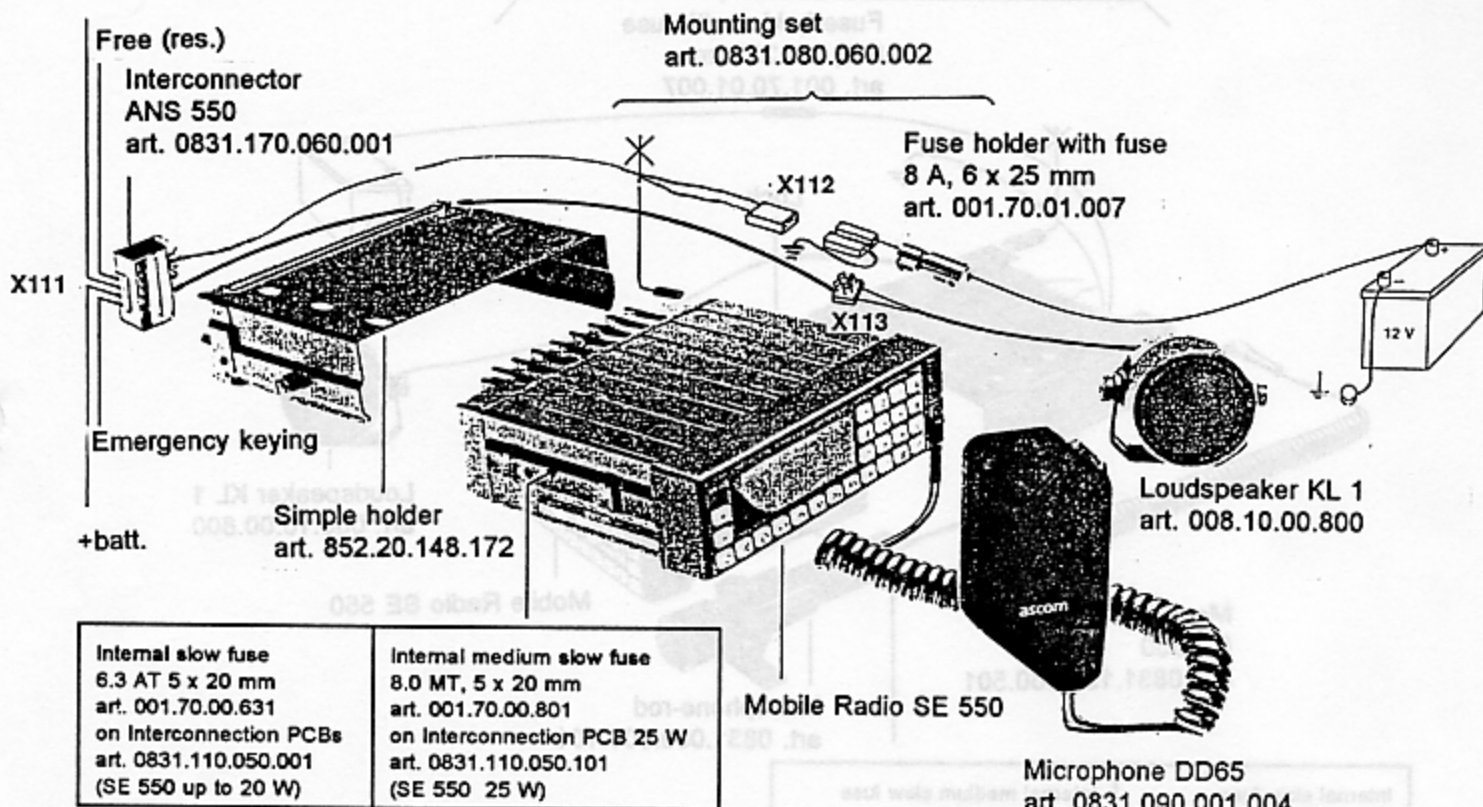

Diagram 1.
Noise loop in power leads

2.10.4 Installation on the Simple Mounting Holder

Signalization AS



ASCOM GmbH
 TECHNICAL HANDBOOK
 SE 550-08-25-1

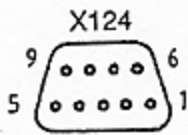
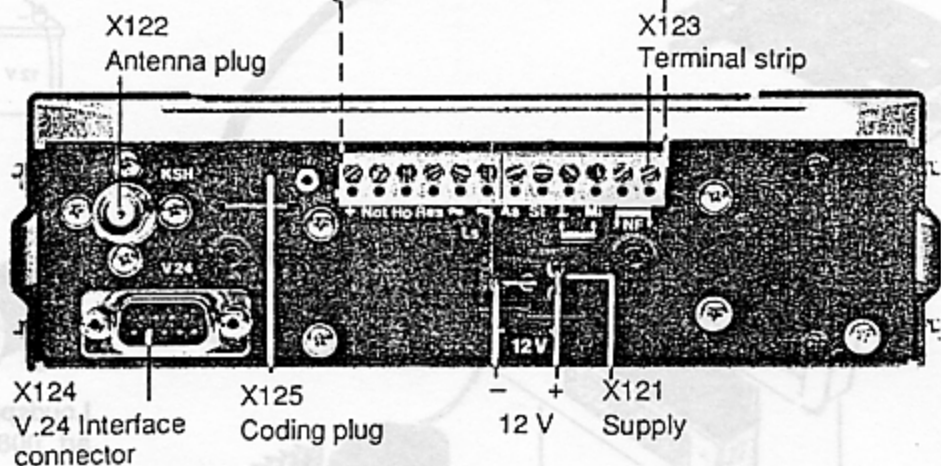
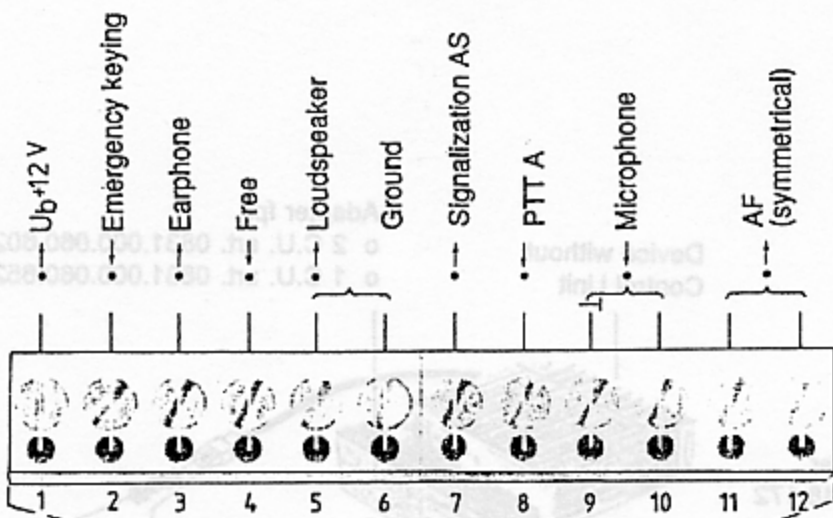

Seen from the connecting side

1	
2	TxD
3	RxD
4	+ UB
5	⊥
6	
7	CTS
8	RTS
9	

2.10.6 Version with Remote Control Unit

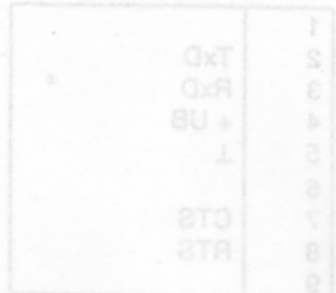
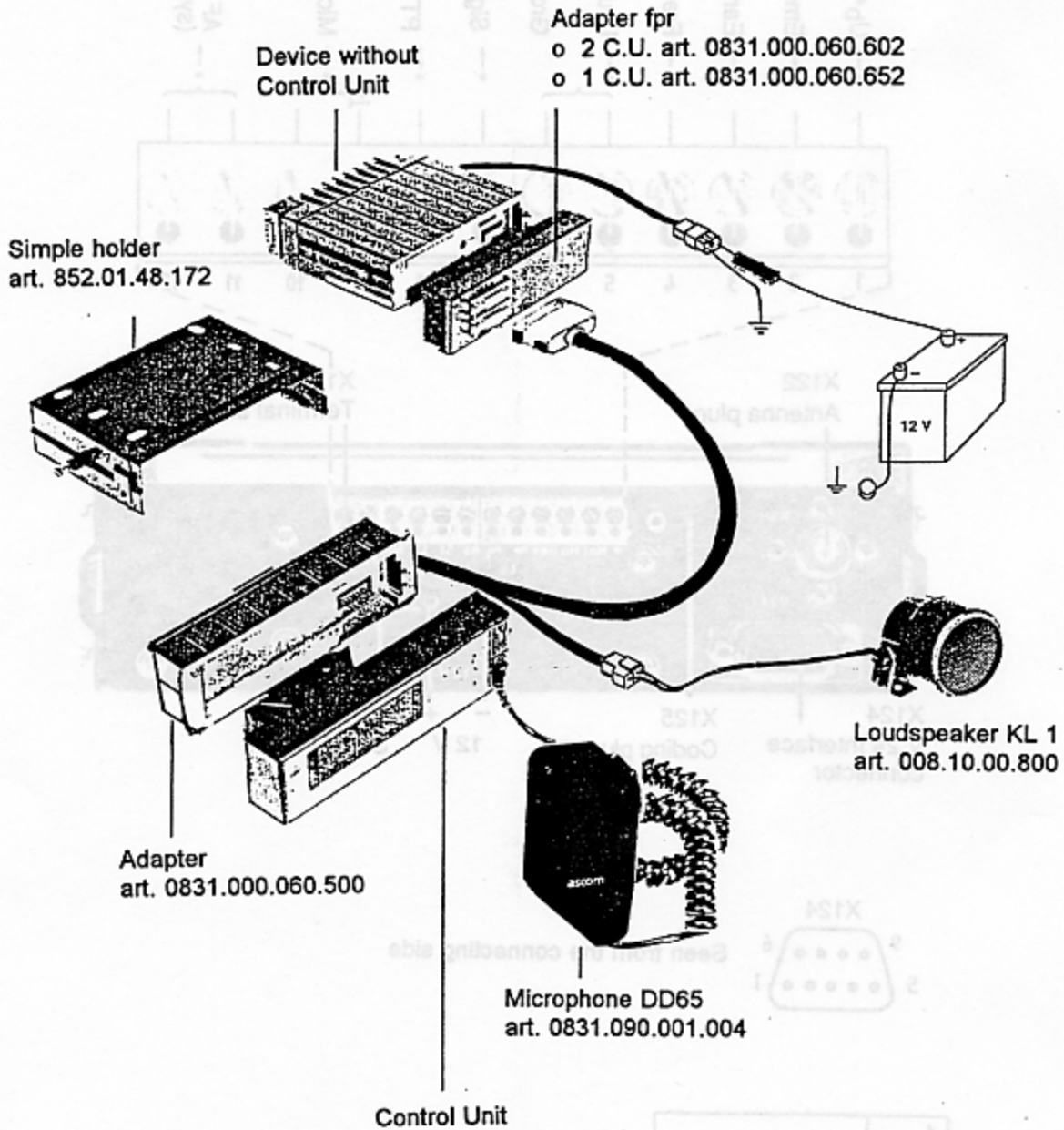

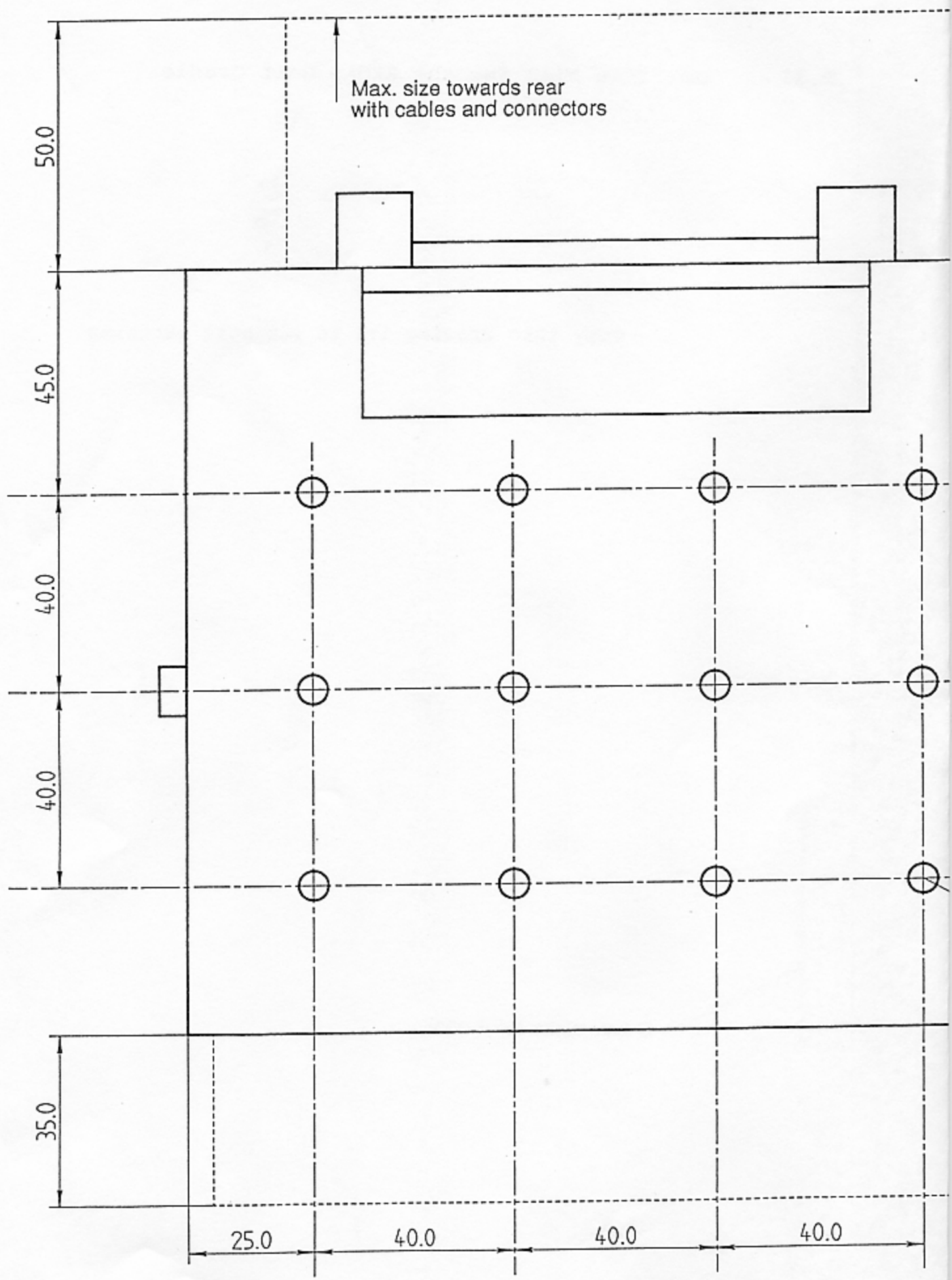

2.11 Drilling Plan for the Radio Unit Cradle

Copy this drawing 1:1 to get hole patterns.

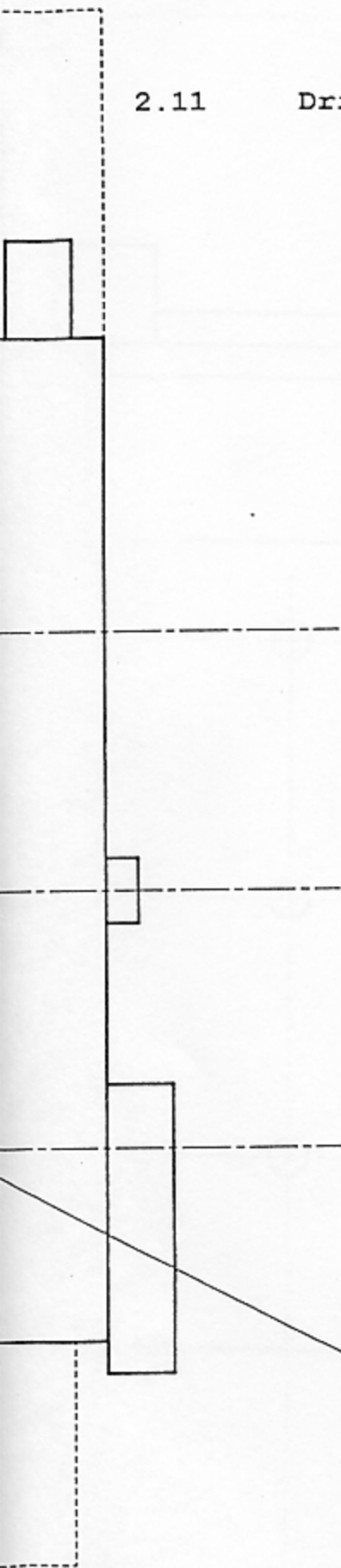

Ø hole diameter: 6 mm

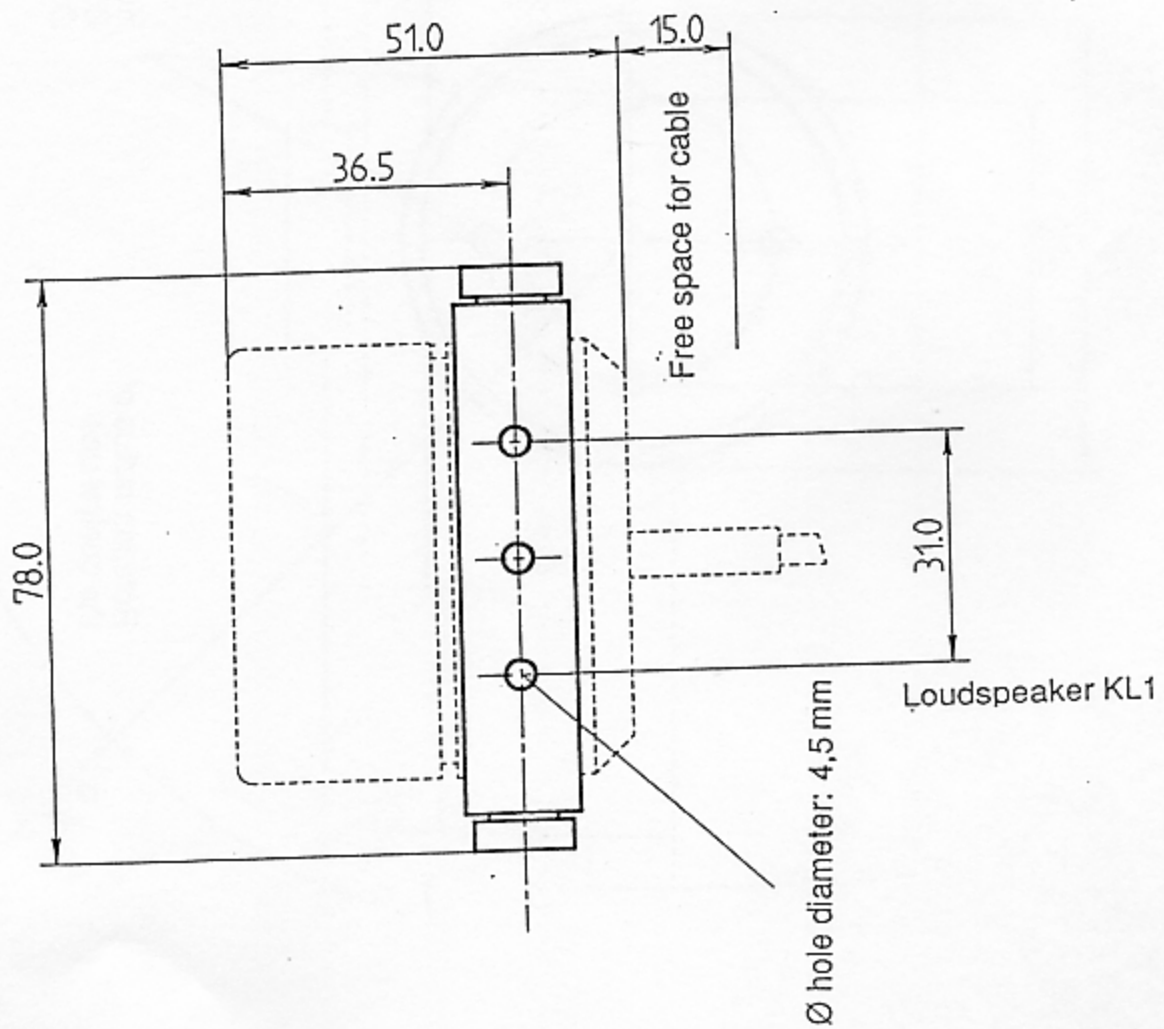
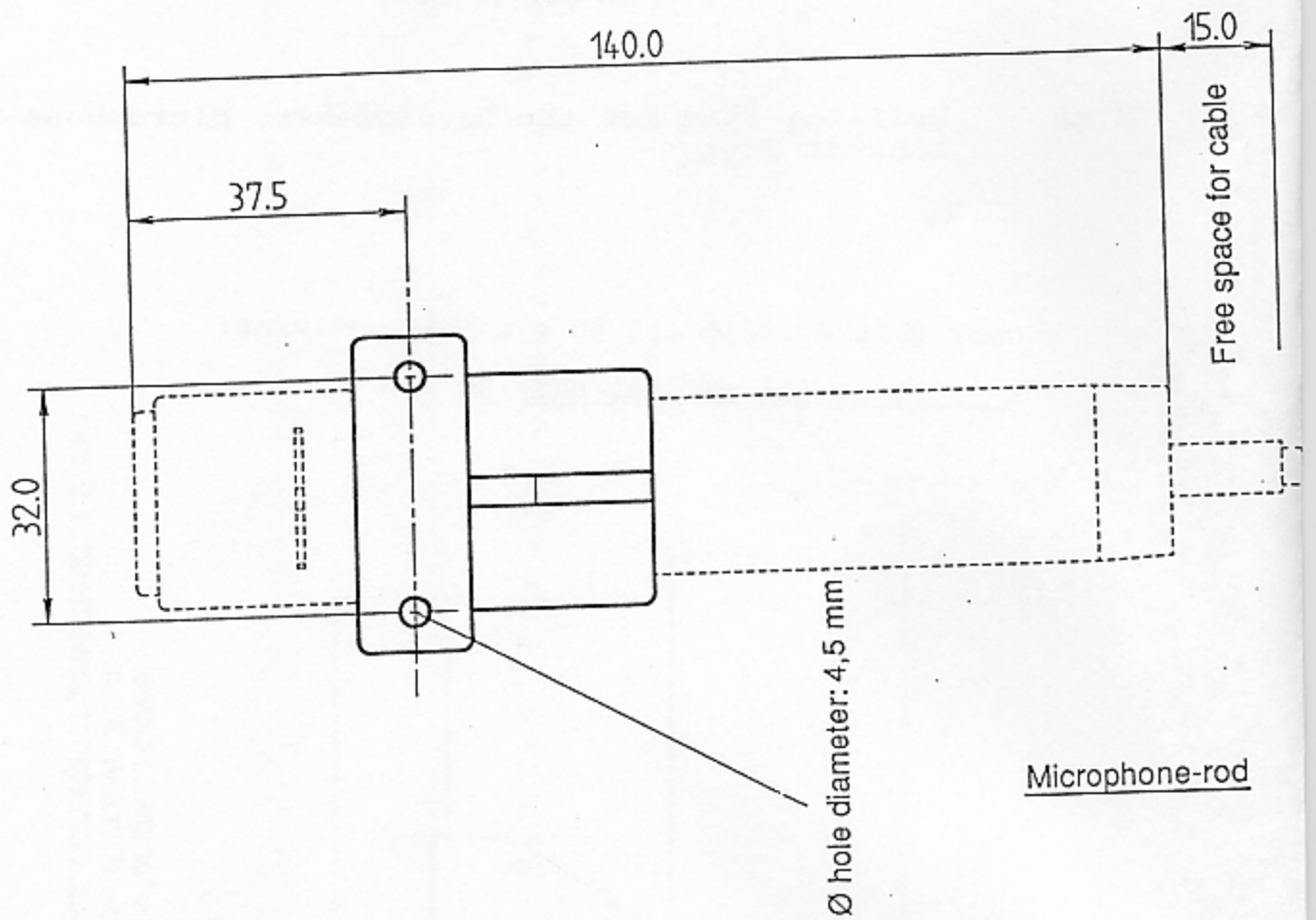

2.12 Drilling Plan for the Loudspeaker, Microphone-Rod,
Control Unit

Copy this drawing 1:1 to get hole patterns.

Support of the control unit BG

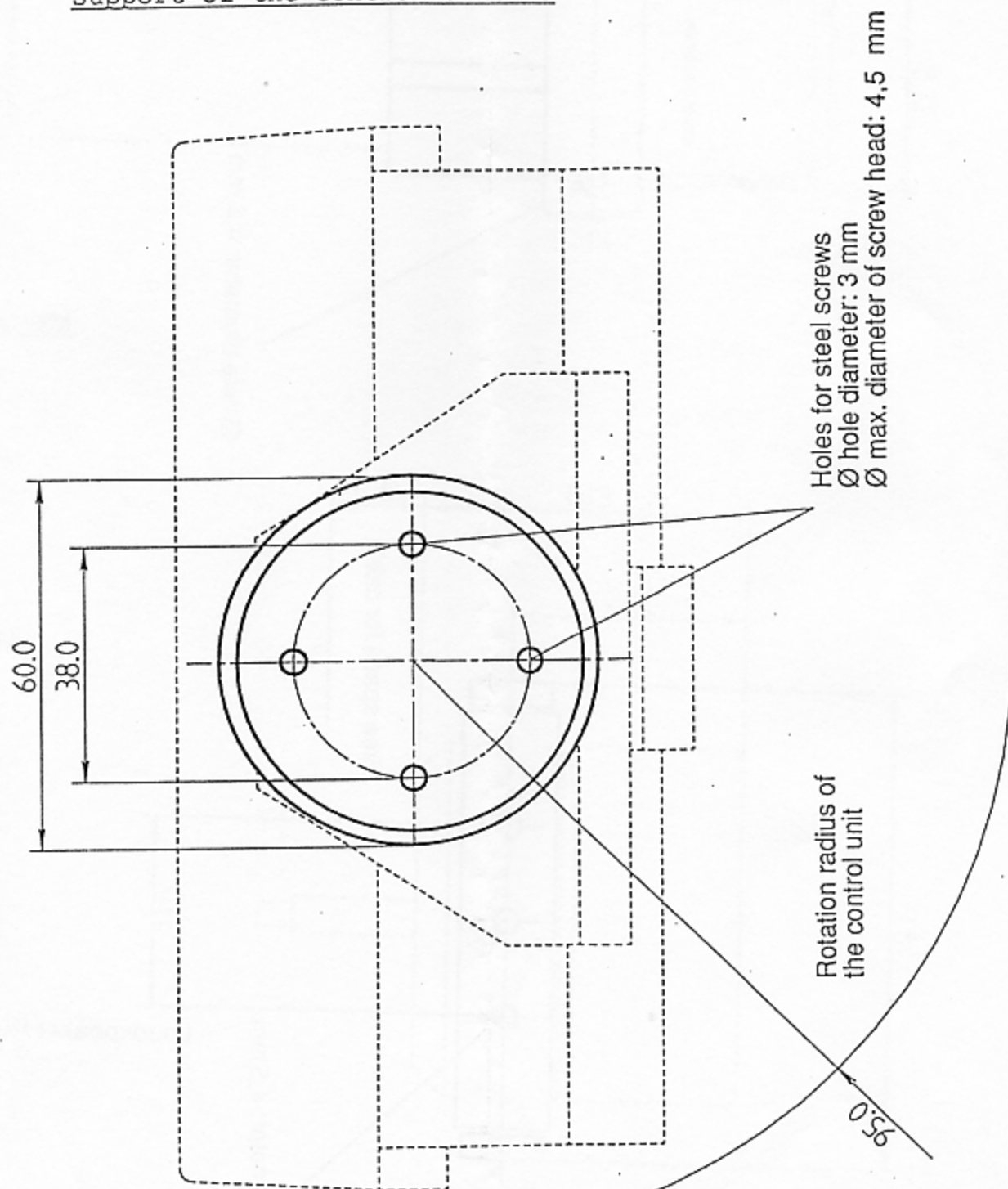

2.13 Accessories (Option)



Microphone DD65
art. 0831.090.001.004
Front plugging

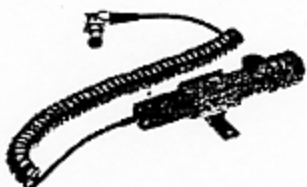

Microphone-rod with
microphone preamplifier
art. 0831.090.001.101
for connection at rear of
the plugging holder
art. 0831.190.060.501

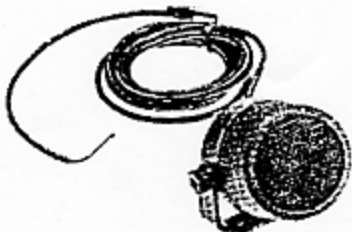

Loudspeaker KL1
art. 008.10.00.800



Coding plug
art. 0831.000.000.941

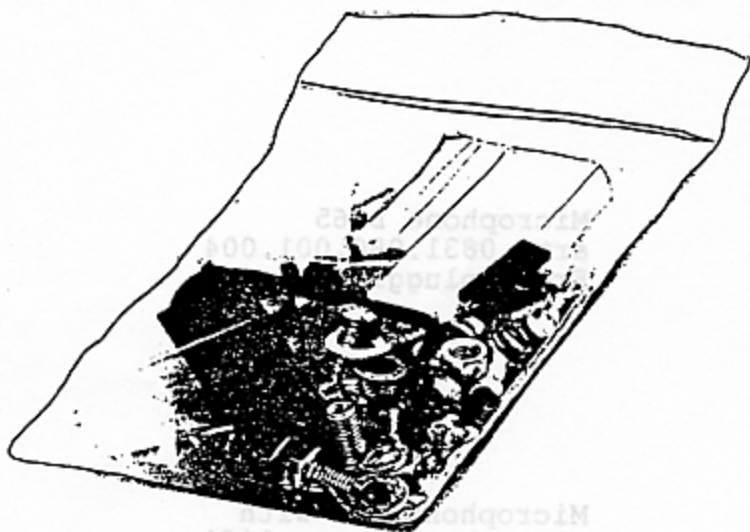

Accessories (Option)

Mounting set
art. 0831.080.060.002

Microphone
microphone preamplifier
art. 0831.090.001.101
for connection at rear of
the plugging holder
art. 0831.190.060.501

Loudspeaker KLI
art. 008.10.00.800

Coding plug
art. 0831.000.000.941